

Butterfly-Control-Valves

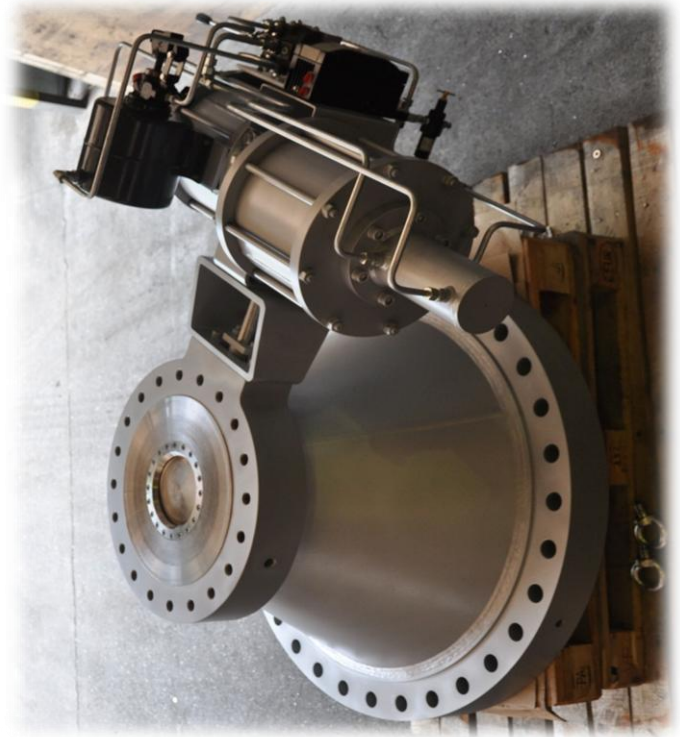

steam power plant

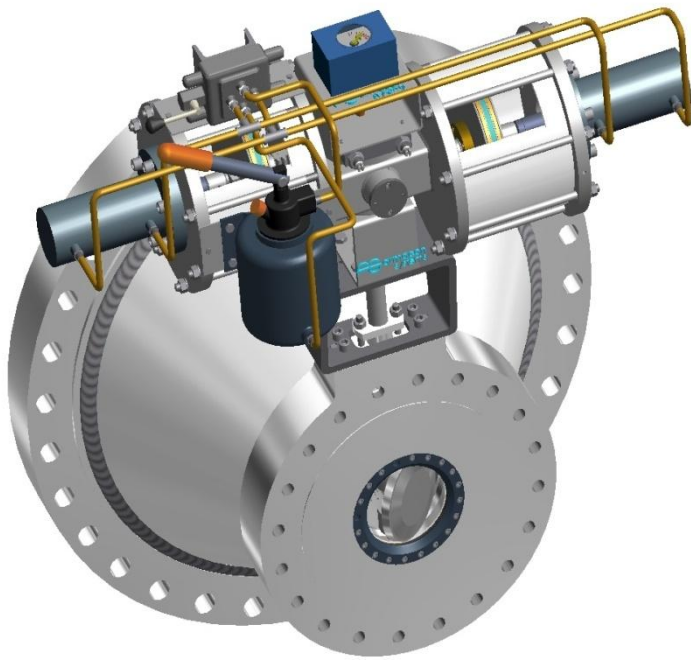
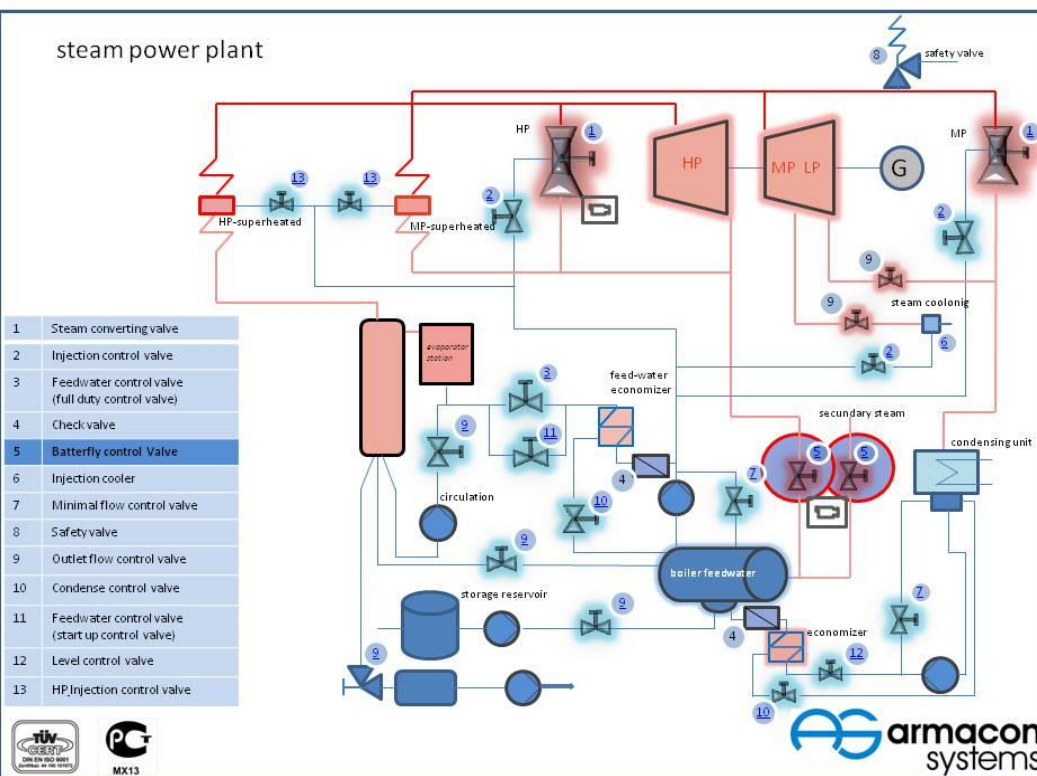

armacon-systems GmbH

Hansapark 1
D-39116 Magdeburg, Deutschland
Tel: 0391 - 244 625 0
Fax: 0391 - 244 625 11
eMail: info@armacon-systems.de

Bankverbindung

Volksbank Börde-Bernburg eG
BLZ 810 690 52,
Kto-Nr. 7324928
BIC GENODEF1WZL
IBAN DE 66 8106 9052 000 732 4928

Geschäftsführerin

Dipl. Ing. Petra Wenig

Handelsregister

AG Magdeburg HRB 14479
USt.-Id.Nr.: DE 237919303
St.-Nr.: 102/105/12921





Design:

- Butterfly Control Valves in common or tri-eccentric design
- Rückfreies Anfahren aus der Schließstellung/ Sensibles Regeln
- High control range
- Different seat diameter for all nominal diameter
- Changeable seats and discs
- Metal-elastic seat for tight closing up to 550°C
- Maintenance free stem sealing according to TA-Luft
- Fire-Safe design
- Annex assembling sets for sound and vibrancy reducing

